

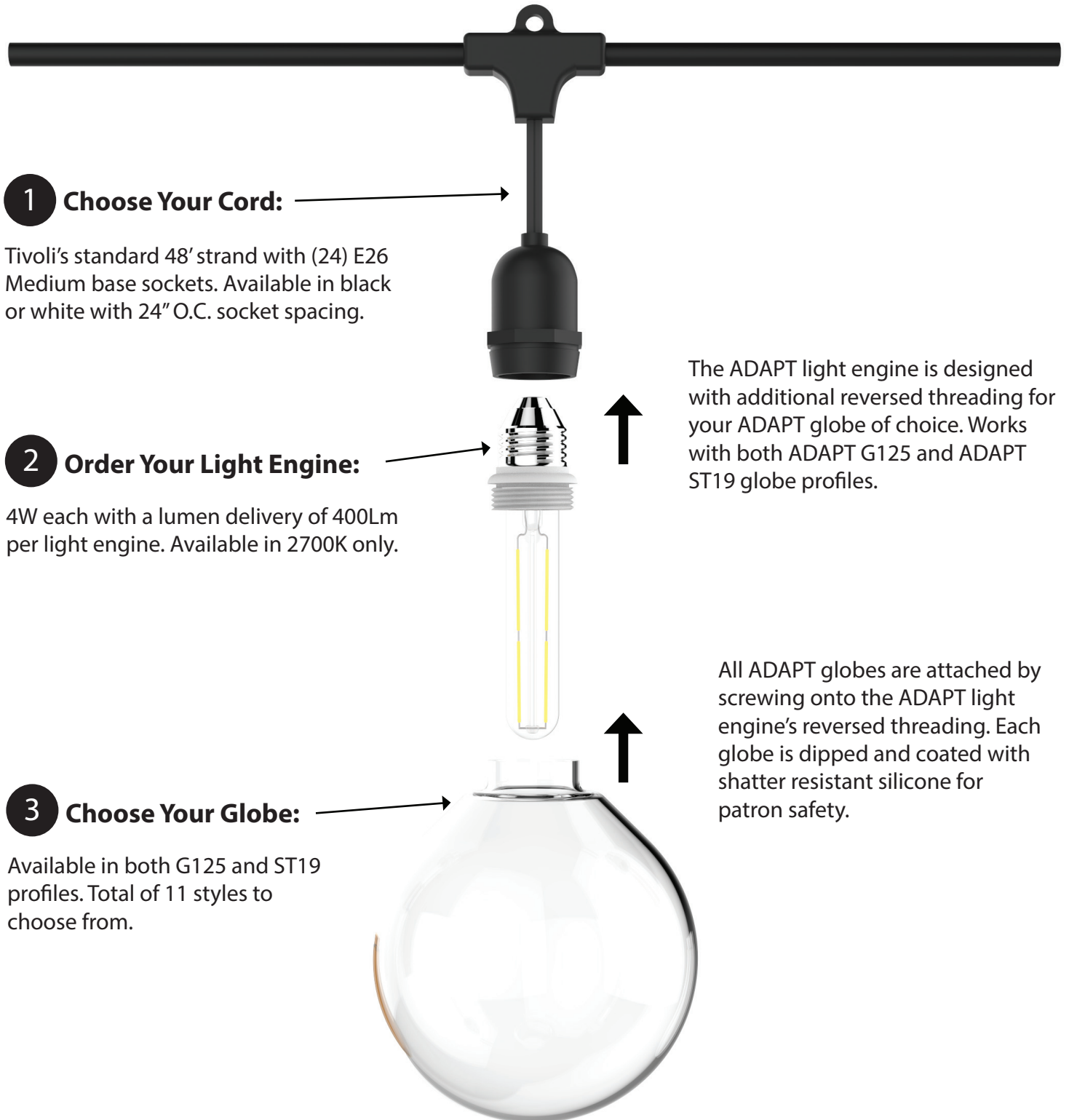

ADAPT
COMMERCIAL STRING LIGHT

ADAPT COMMERCIAL STRING LIGHT- How it works

Simply choose your cord color, light engine and globe choice for over 20 design combinations to create a unique experience for personal or public space.



1 Choose Your Cord:

Tivoli's standard 48' strand with (24) E26 Medium base sockets. Available in black or white with 24" O.C. socket spacing.

2 Order Your Light Engine:

4W each with a lumen delivery of 400Lm per light engine. Available in 2700K only.

3 Choose Your Globe:

Available in both G125 and ST19 profiles. Total of 11 styles to choose from.

The ADAPT light engine is designed with additional reversed threading for your ADAPT globe of choice. Works with both ADAPT G125 and ADAPT ST19 globe profiles.

All ADAPT globes are attached by screwing onto the ADAPT light engine's reversed threading. Each globe is dipped and coated with shatter resistant silicone for patron safety.



1 Choose Your Cord

Standard 48' strand with E26 Medium base sockets. Available in black or white with 24" O.C. spacing and 24 socket count.



Strand



120V AC



Warranty

Socket On Center Spacing	24"
Length (with male and female ends)	48'
Field Cuttable	No
Watts per Strand / Filament Light Engine	96 Watts
E26 Socket Type Count	24
Cord Type	3C x 14AWG SJTW
Operating Voltage	120V
Plug	5-15P Polarized
Available Color	Black, White
Cord Weight	7.85 lbs.
Mounting	Indoor/Outdoor



24" OC Connecting Multiple Light String On Single Run (MAX RUN)			
Light Engine	Strand Sets	Feet	Watts
Filament	8	384'	768'

Based on 10% Voltage Drop

Order Information

COMMERCIAL STRAND 24" O.C. w/24 socket count.
TCSL-S-B-24-120

48' 120V Commercial Strand BLACK cord, 24" OC spacing.

TCSL-S-W-24-120

48' 120V Commercial Strand WHITE cord, 24" OC spacing.

2 Order Your Light Engine

LED Filament Light Engine (each)				
Lifetime Hours	Watts	Lumens	Weight	Kelvin Temperature
15000	4W	400 Lm	.10lbs	2700K

Order Information

ALS-TF-T25-E26-4W-27K-6PK-R

Filament Light Engine - Sold as 6 Pack with (1) rubber O-Ring per Bulb.



CRI



E26
Medium Base



120V AC



Dimmable



Note: Consult Factory for Dimmer compatibility options



Standard Spacing and Weights

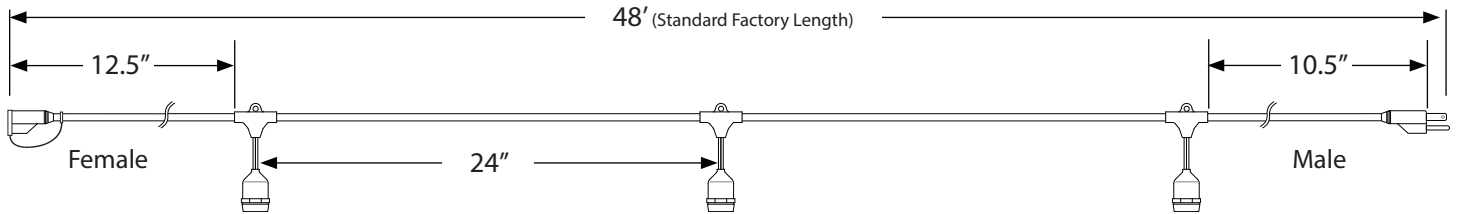

Filament Light Engine and ST19 Total Weight w/48 ft. Strand

12.65 lbs.

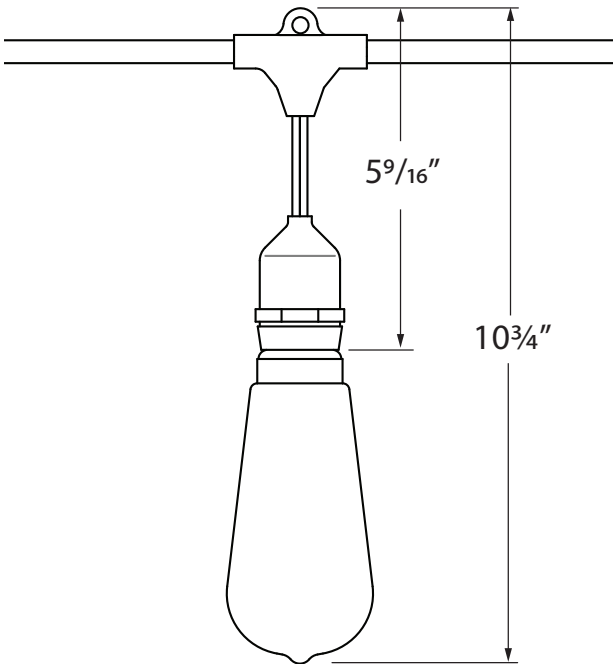

Filament Light Engine and G25 Total Weight w/48 ft. Strand

16.25 lbs.

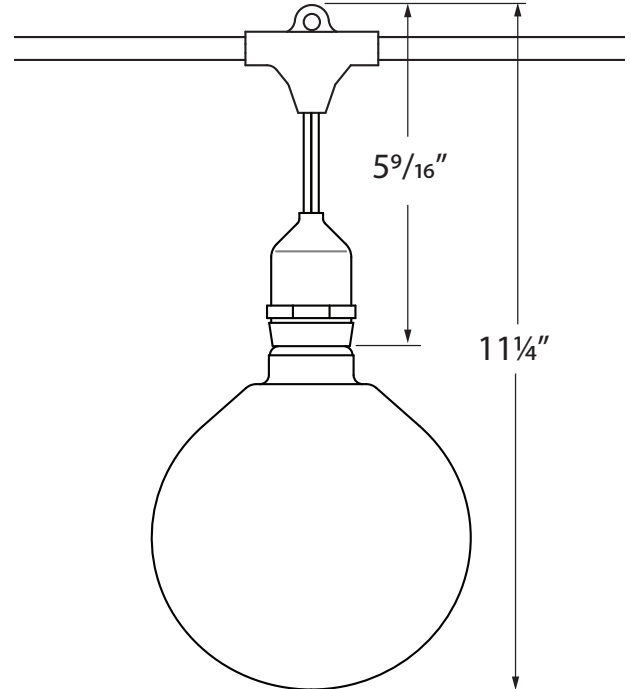

3 Choose Your Globe - Sold each



Shatter Resistant Silicone Coating
(Shatter resistance assist with silicone coating - Glass may still break under certain conditions)

G125 Globe (Weight: .25 lbs/ea.)



Ana
LSA-ANA-N



Angela
LSA-ANG-N



Gina
LSA-GIN-N



Gaby
LSA-GAB-N



Katie
LSA-KAT-N



Susan*
LSA-SUS-N



Toni*
LSA-TON-N



Lucia*
LSA-LUC-N



Victoria*
LSA-VIC-N

ST19 Globe (Weight: .10 lbs/ea.)



Brenda
LSA-BRE-N



Shatter Resistant
Silicone Coating



Laura*
LSA-LAU-N

*Consult Factory for MOQ and Lead Time.

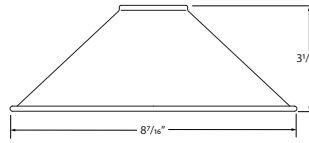
Light Shades
HAT

SHADE-HT-BK-BK-8
Light Shade - HAT
8.3" Black Top, Black Bottom

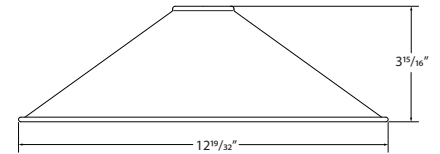

SHADE-HT-BK-BK-13
Light Shade - HAT
12.6" Black Top, Black Bottom
***SHADE-HT-BK-CO-13**
Light Shade - HAT
12.6" Black Top, Copper Bottom

*Consult factory for lead time and MOQ

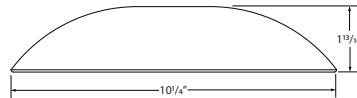
DISH

SHADE-DS-BK-BK-10
Light Shade - DISH
10.2" Black Top, Black Bottom

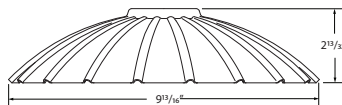
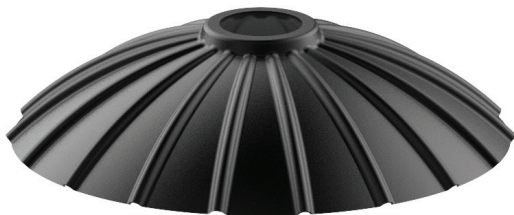
FLOWER

SHADE-FL-BK-BK-10
Light Shade - FLOWER
9.8" Light Shade, Black Top, Black Bottom

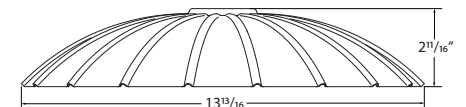

SHADE-FL-BK-BK-13
Light Shade - FLOWER
13.8" Light Shade, Black Top, Black Bottom

Accessories

SHADE-ADP-CSL-BK-25 Light Shade Adapter
PVC Black Adapters - Sold in packs of 25
Comes with (25) Adapters, (50) set screws and (1) Allen Key.

SHADE-ADP-CSL-BK-01 Light Shade Adapter
PVC Black Adapters - Sold individually
Comes with (1) Adapters, (2) set screws and (1) Allen Key.

*Consult factory for lead time and MOQ

Mounting

WARNING: For suspension application, catenary cable is required to support the product, otherwise the warranty will be void.



LS-CABLE-60 Catenary Cable Kit - 60'
(1/8" galvanized aircraft cable includes 2 cables locks for use with loads up to 200lbs)

LS-CABLE-110 Catenary Cable Kit - 110'
(1/8" galvanized aircraft cable includes 2 cables locks for use with loads up to 200lbs)

LS-CABLE-500 Catenary Cable Kit - 500'
(1/8th" galvanized aircraft cable for use with loads up to 200lbs)



LS-LOCK-X Cable Lock
X = 2 (2 Locks), 4 (4 locks) Includes (1) cable release key.
Cable Lock for 1/8th inch cable, Heavy-duty lockable fasteners support loads up to 200 lbs. Can be easily adjusted without the use of tools.



LS-TT Catenary Tensioning Tool
Catenary Cable Tensioning Tool up to 880lbs with minimal effort due to the 6:1 gear drive mechanism. Integral torque gauge controls the load applied to the wire, giving consistent tension every time and optimizing the life of the wire.



LS-UVZP-BK-50 UV Zip Ties
50 pc Bag set. UV resistant, heavy duty ties. Maximum weight up to 100 lbs./per tie.



LS-UVZP-BK-30 UV Zip Ties
30 pc Bag set. UV resistant, heavy duty ties. Maximum weight up to 100 lbs./per tie.

Installation with Suspension Cable

